

DETAIL B

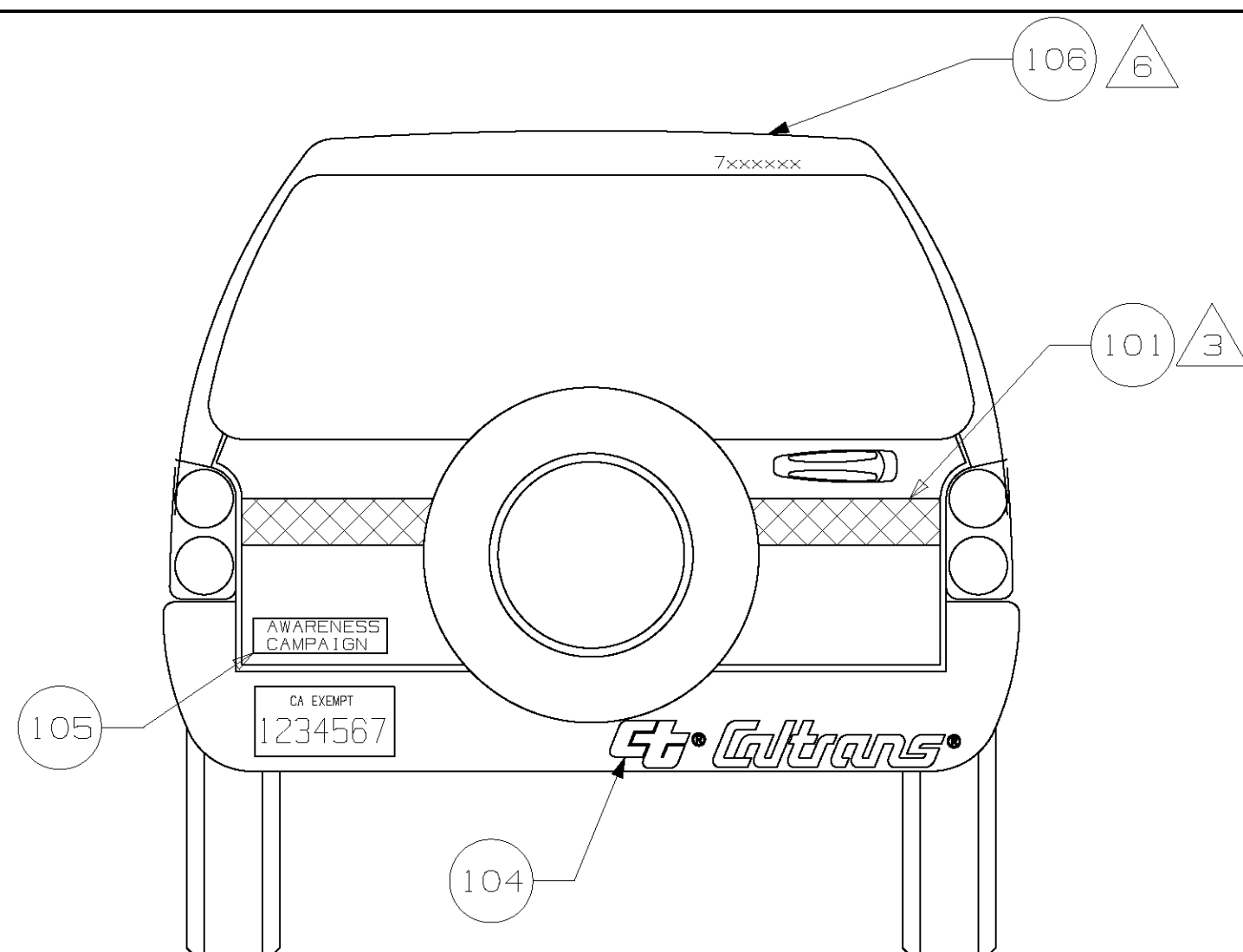

REAR VIEWS

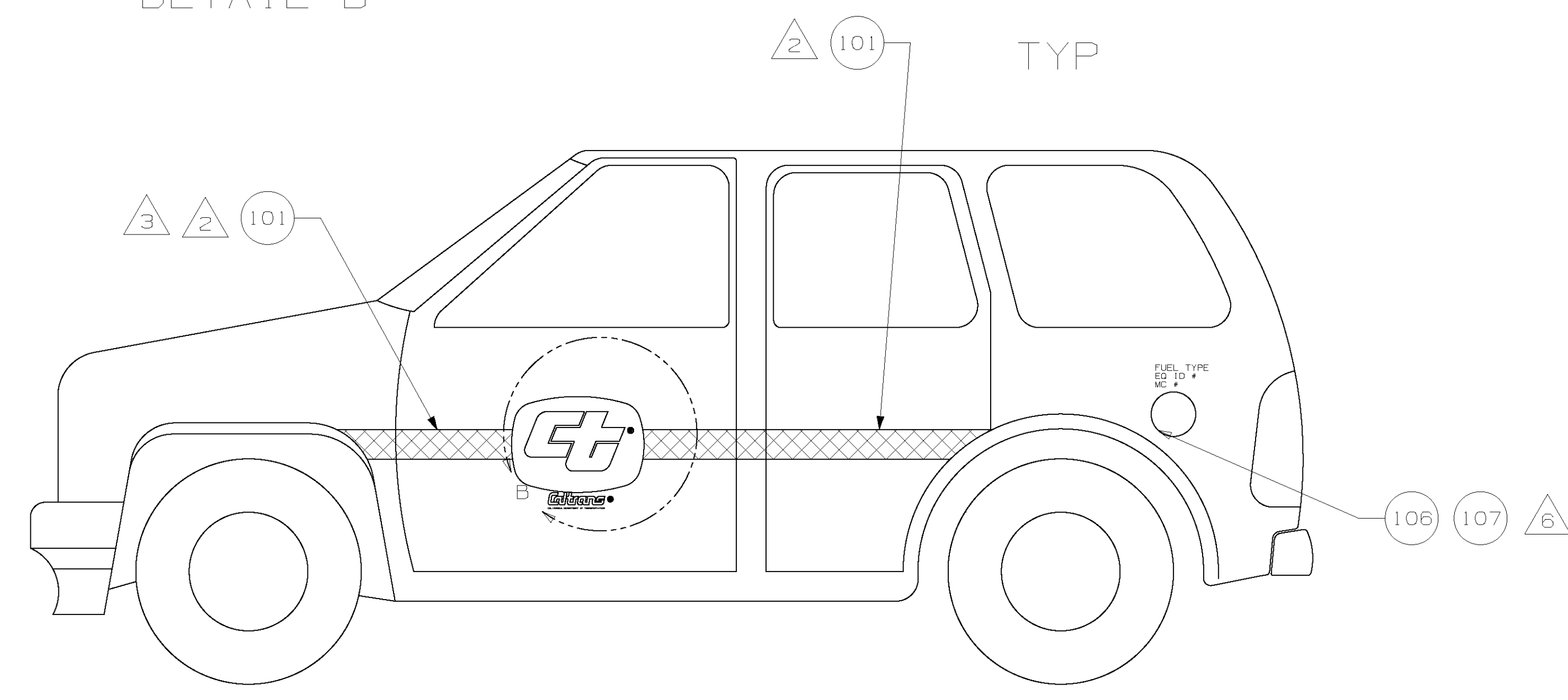

DRIVER SIDE VIEW
PASSENGER SIDE - SAME DECALS

BILL OF MATERIALS				
ITEM	QTY	DESCRIPTION	MF'R #/ CT DWG #	CT STK #
101	AS REQ'D	DECAL, REFLECTIVE SHEET, ORANGE, 4" WIDE	MATERIAL PER SPECIFICATION	053-4767
102	2	DECAL, "CT" DOOR, WHITE REFLECT, 7" x 9"	03-0004-01	053-4761
103	2	DECAL, "CALTRANS" BLACK SCRIPT, 2"	03-0005-01	053-4764
104	1 OR 1	DECAL, "CT CALTRANS" ORANGE SCRIPT, 3"	03-0014-01	053-4802
		DECAL, "CT CALTRANS" WHITE SCRIPT, 3"	03-0014-01	053-4752
105	1	APPROVED PUBLIC AWARENESS CAMPAIGN BUMPER STICKER	.	.
106	1	EQ ID # & MC # - SPECIAL ORDER	.	053-4892
107	1 OR 1	FUEL TYPE DECAL - E85 OR GASOLINE	.	053-4990
		FUEL TYPE DECAL - UNLEADED FUEL ONLY	.	053-1510

NOTES:

- 1 ALL DELINEATION WILL BE IN COMPLIANCE WITH CALTRANS EQUIPMENT QUALITY STANDARDS. GO TO www.dot.ca.gov/hq/eqsc AND CLCK ON THE LINK "EQUIPMENT QUALITY STANDARDS" THEN "FLEET IDENTIFICATION"
- 2 STRIPING APPLICATION: ALL STICKERS, LABELS AND STRIPING SHALL BE LEVEL, STRAIGHT, BUBBLE-FREE AND DEBRIS-FREE. NO SPLICING OF TAPE OR STRIPING SHALL BE ACCEPTABLE. ALL EDGES ON STRIPING SHALL BE TRIMMED 1/8-3/8 INCH FROM THE EDGES OF DOORS, PANELS, FENDERS, LIGHTS, EMBLEMS, ETC. ORANGE REFLECTIVE SHEETS (ITEM 101) AND STRIPING SHALL BE TRIMMED TO MATCH BODY CONTOURS AND CREASES WHEN IT WILL NOT LAY HORIZONTAL. ANY REFLECTIVE TYPE OF STRIPE OR STICKER SHALL NOT BE PULLED FROM THE VEHICLE AND REAPPLIED DURING APPLICATION, SINCE THE REFLECTIVE MATERIAL WILL BE COMPROMISED.
- 3 PLACE LOWER EDGE OF ITEM 101 APPROXIMATELY 1/2 WAY BETWEEN THE BOTTOM OF THE WINDOW AND THE BOTTOM OF DOOR. MAKE ADJUSTMENT SLIGHTLY AS REQUIRED TO CLEAR FENDER CUTOUTS AND OTHER FEATURES TO IMPROVE EASE OF INSTALLATION. ITEM 101 POSITION MAY BE ADJUSTED SLIGHTY TO ALIGN WITH BODY STRIPE IF POSSIBLE
- 4 ITEM 102: LOCATE SUCH THAT THE LOGO IS CENTERED ON THE VERTICAL CENTERLINE OF THE DOOR AND ON THE STRIPE (ITEM 101). STRIPE 101 TO BE TRIMMED TO MATCH EDGES OF ITEM 102
- 5 ITEM 103 TO BE LOCATED BELOW THE "CT" LOGO AND ALONG THE VERTICAL CENTERLINE OF THE DOOR.
- 6 THE FOLLOWING DECAL GROUP SHALL BE PLACED DIRECTLY ABOVE OR NEXT TO EACH FUEL FILLER IN ORDER FROM TOP TO BOTTOM: FUEL TYPE, EQ. ID, MC#

COPYRIGHT 2015 CALIFORNIA DEPARTMENT OF TRANSPORTATION. ALL RIGHTS RESERVED
THIS DOCUMENT CONTAINS CONFIDENTIAL AND PROPRIETARY INFORMATION THAT CANNOT BE REPRODUCED OR DIVULGED, IN WHOLE OR IN PART, WITHOUT WRITTEN AUTHORIZATION FROM CALTRANS DIVISION OF EQUIPMENT, OFFICE OF ENGINEERING AND PRODUCTION

REV	DESCRIPTION	BY
NEXT ASSEMBLY		
STATE OF CALIFORNIA DEPARTMENT OF TRANSPORTATION DIVISION OF EQUIPMENT		
SPORTS UTILITY VEHICLE, SMALL DELINEATION		
TOLERANCE-UNLESS OTHERWISE SPECIFIED	SCALE NONE	DATE 24 Aug 15
DECIMAL ±	DRAWN Down/n/Payne	DESIGNED CAL
FRACTIONAL ±	CHECKED	APPROVED
ANGULAR ±		
DRILLED HOLES ±		
REAMED HOLES ±		
		I-00580-DE
		SHEET 1 OF 1 SHEETS

MAINTENANCE CLASS 00490 – RAV4 MINI SUV



MAINTENANCE CLASS 00490 – RAV4 MINI SUV



MAINTENANCE CLASS MC10580 SUV Small Size 4x4 Gas



MAINTENANCE CLASS MC10580 SUV Small Size 4x4 Gas







MAINTENANCE CLASS 10580 SUV, SMALL SIZE, 4x4, GAS



MAINTENANCE CLASS 10580 SUV, SMALL SIZE, 4x4, GAS



MAINTENANCE CLASS 10580 SUV, SMALL SIZE, 4x4, GAS



MAINTENANCE CLASS 10580 SUV, SMALL SIZE, 4x4, GAS

